



## CAUTION: Equipment Damage

These procedures should be done by a qualified installer who is trained on programming inverter power systems. Failure to set accurate parameters for the system could potentially cause equipment damage. Damage caused by inaccurate programming is not covered by the limited warranty for the system.



## IMPORTANT

Check the firmware revision of all OutBack devices before use. The Radian inverter and MATE3 system display may not communicate or operate correctly unless their firmware is above a specified revision number.

For models GS8048A and GS4048A, the firmware must be revision 001.005.xxx or higher.

The MATE3 must be revision 002.017.xxx or higher.

The MATE3 Configuration Wizard allows quick setup of parameters that apply to all systems. The Configuration Wizard is reached from the MATE3 Main Menu as shown to the right.

The firmware revision of all devices can be confirmed by navigating from the MATE3 Main Menu as shown below. Upgrades to the firmware revision can be downloaded from the OutBack website [www.outbackpower.com](http://www.outbackpower.com).

## Firmware Revision

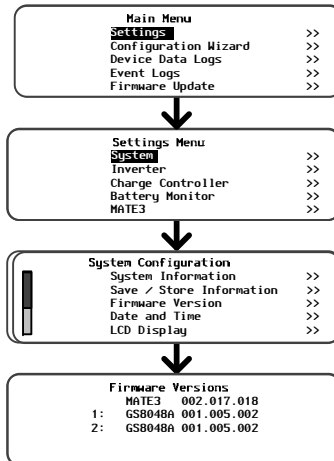

## Configuration Wizard

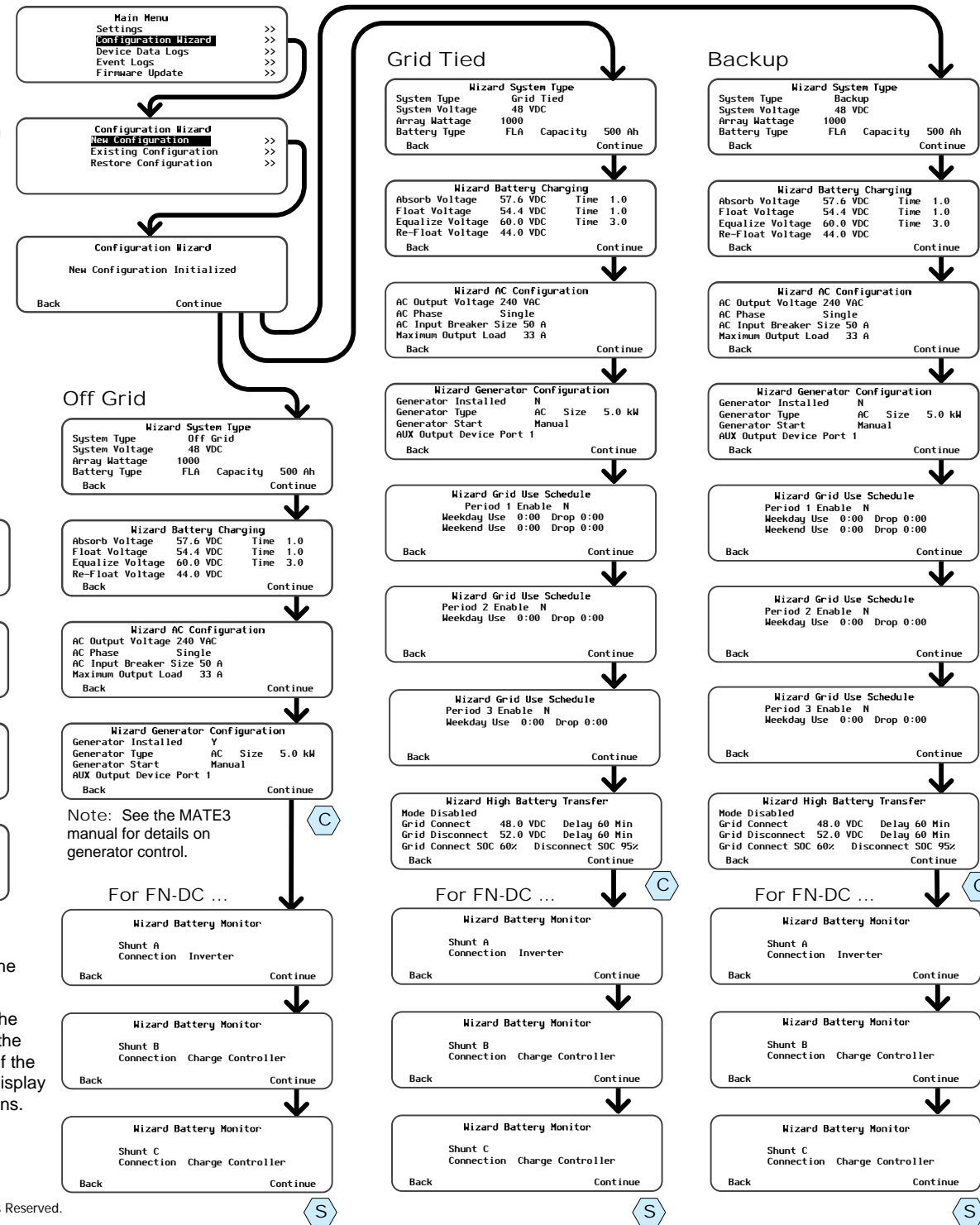

**S** This advances the display to the Setup Complete screen.

**C** This advances the display to the Setup Complete screen if the FLEXnet DC is not installed. If the FLEXnet DC is installed, the display advances to the Shunt screens.



## WARNING: Fire/Explosion Hazard

Do not place combustible or flammable materials within 12 feet (3.7 m) of the equipment. This unit employs mechanical relays and is not ignition-protected. Fumes or spills from flammable materials could be ignited by sparks.



## WARNING: Personal Injury

Use safe lifting techniques and standard safety equipment when working with this equipment.



## IMPORTANT:

Clearance and access requirements may vary by location. Maintaining a 36" (91.4 cm) clear space in front of the system for access is recommended. Consult local electric code to confirm clearance and access requirements for the specific location.

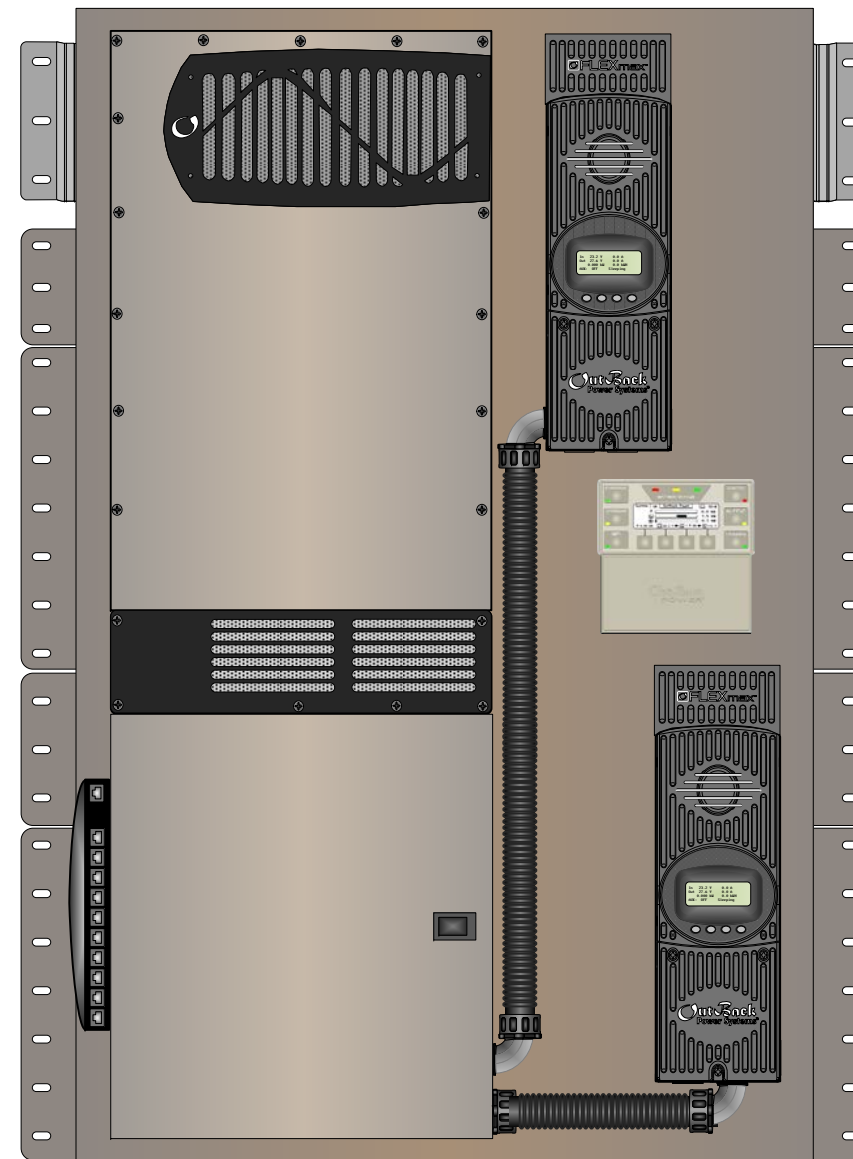

Contact Technical Support:  
 Telephone: +1.360.618.4363  
 Email: Support@outbackpower.com  
 Website: www.outbackpower.com

## Components Included

FPR-8048A	
Inverter/Charger	GS8048A
GS Load Center	GSLC175-PV-120/240
Charge Controller	FM80-150VDC (x 2)
FPR-4048A	
Inverter/Charger	GS4048A
GS Load Center	GSLC175-PV1-120/240
Charge Controller	FM80-150VDC (x 1)
All Models	
System Display and Controller	MATE3 (with FW-MB3-S mounting bracket)
Communications Manager	HUB10.3
Battery Monitor	FLEXnet DC (FN-DC)
Remote Temperature Sensor (RTS)	
Wall Mount Bracket	
Pre-wired Back Plane	

## Customer-Supplied Components

AC Source	Utility Grid or AC Generator
Main Electrical Panel (or overcurrent device for the AC source)	
Electrical Distribution Subpanel (Load Panel)	
Photovoltaic (PV) Array and Combiner	
Battery Bank	

**IMPORTANT:**  
 Not intended for use with life support equipment.



Masters of the Off-Grid.™  
 First Choice for the New Grid.

NOTE: Working gloves are strongly recommended when performing installation steps.

- 1 Ensure the mounting surface is strong enough to handle 3 times the total weight of all the components. Add plywood or other reinforcing material as necessary to strengthen the surface.
- 2 Attach the wall bracket. Center the mounting holes on the wall studs. Use all 6 mounting screws to secure the bracket.
- 3 Lift the inverter high enough that the inverter bracket is above the wall bracket.
- 4 Lower the inverter so that the top of the back plane flange slips into the wall bracket. Ensure the unit is centered on the wall bracket.
- 5 Install the mounting screws. See illustration below for preferred locations for maximum mounting strength.

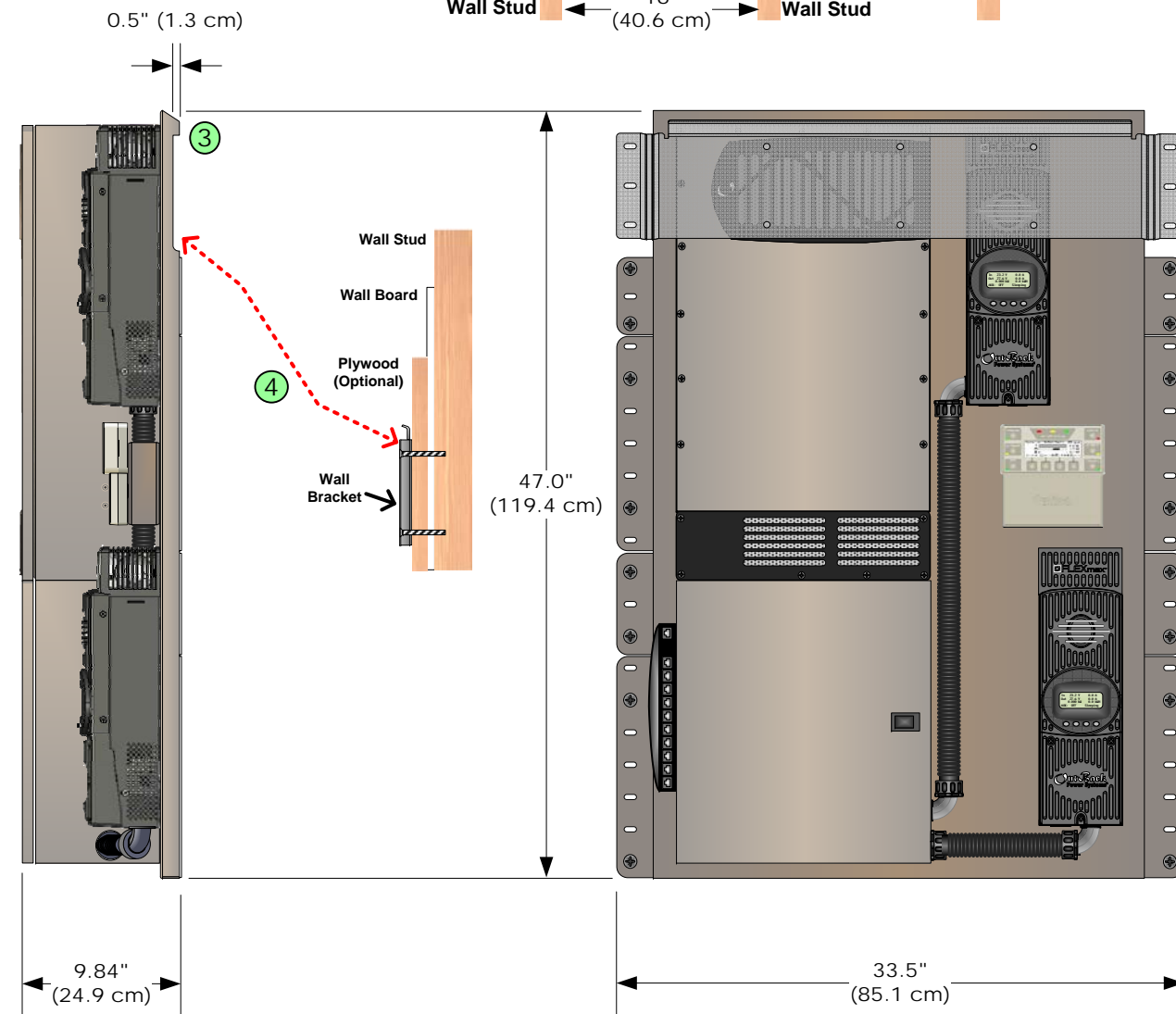
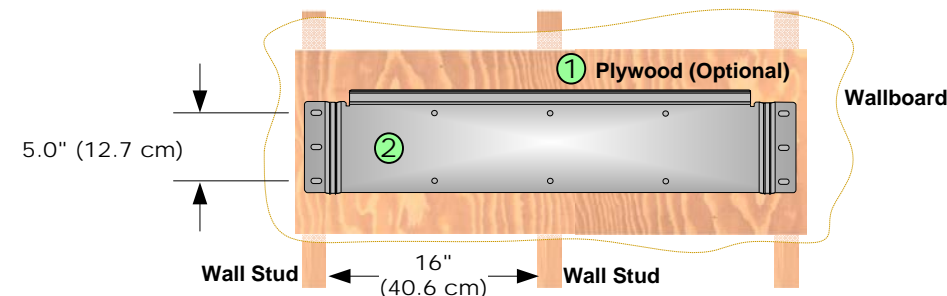

5 Preferred screw locations are depicted here

### AC Wire Sizes and Torque Values

Wire Size		Torque	
AWG	mm <sup>2</sup>	In-lb	Nm
#14 to #10	2.5 to 6	20	2.3
#8	10	25	2.8
#6 to #4	16 to 25	35	4.0
#3	35	35	4.0
#2	35	40	4.5
#1	50	50	5.6
1/0	70	50	5.6

OutBack recommends that conductors be #6 AWG THHN copper, or larger, rated to 75°C (minimum) unless local code requires otherwise.

### Minimum DC Cable based on the DC Circuit Breaker

Circuit Breaker	Cable Size	Torque	
		In-lb	Nm
60	#6 AWG (16 mm <sup>2</sup> )	35	4.0
80	#4 AWG (25 mm <sup>2</sup> )	35	4.0
125	1/0 (70 mm <sup>2</sup> )	50	5.6
175	2/0 (70 mm <sup>2</sup> )	225	25.4
250	4/0 (120 mm <sup>2</sup> )	225	25.4

### Torque Requirements

Circuit Breaker Stud	Torque	
	In-lb	Nm
M8	20	2.3
1/4 - 20	35	4.0
5/16 - 18	50	5.6
3/8 - 16	225	25.4

DC Plates	Torque	
	In-lb	Nm
Upper holes (+)	60	6.8
Lower holes (+)	50	5.6
Shunt Bolts (-) and GS-SBUS	60	6.8

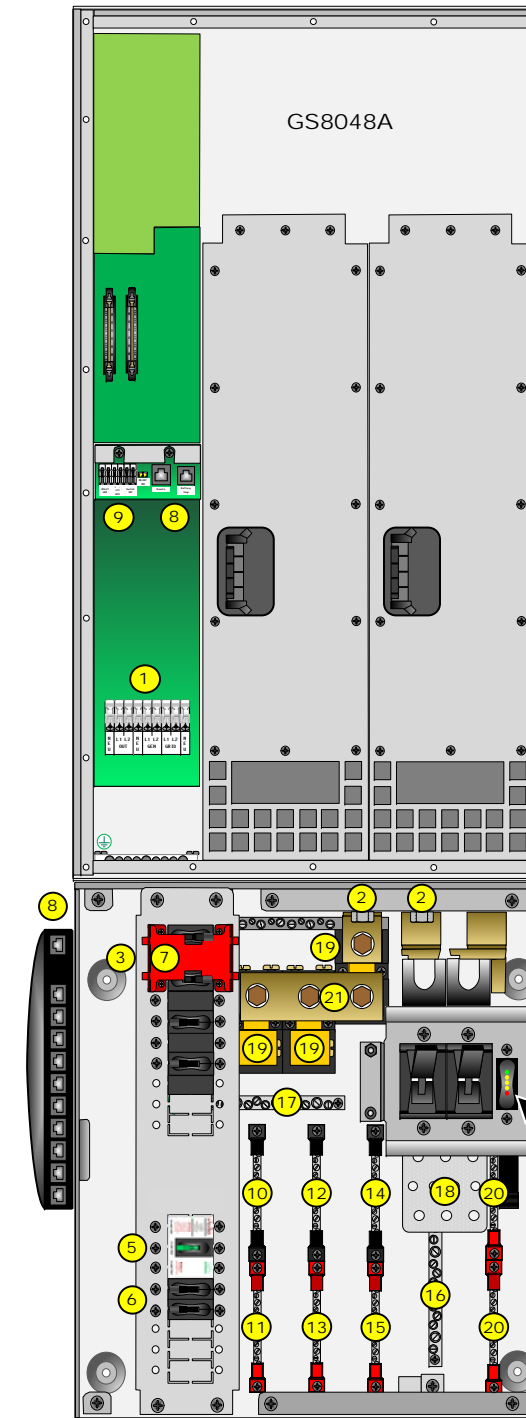

- 1 AC Terminals - Inverter
- 2 DC Terminals - Inverter
- 3 AC Circuit Breakers
- 4 DC Circuit Breakers
- 5 Ground Fault Detector-Interrupter (GFDI)
- 6 PV Circuit Breakers
- 7 Mechanical Interlock (Bypass)
- 8 Communication Ports
- 9 Auxiliary Terminals
- 10 AC OUT Bus Bar L1
- 11 AC OUT Bus Bar L2
- 12 GRID IN Bus Bar L1
- 13 GRID IN Bus Bar L2
- 14 GEN IN Bus Bar L1
- 15 GEN IN Bus Bar L2
- 16 AC Neutral
- 17 Ground
- 18 DC Positive (+) Plate (not used on FPR-4048A)
- 19 PV Negative (-) Terminals
- 20 PV Positive (+) Bus Bars
- 21 DC Negative (-) Plate (GS-SBUS)

NOTE: The AC neutral bus bar (16) is bonded to the GSLC chassis. If the distribution panel neutral is bonded to ground, remove the bond from the neutral bus bar.

FN-DC

FN-DC LED Indicators	
Color	Battery State of Charge
Green	> 90% (blinks if charge parameters are met)
Yellow	≥ 80%
Yellow	≥ 70%
Yellow	≥ 60%
Red	≥ 60% off, < 60% solid, < 50% blinks

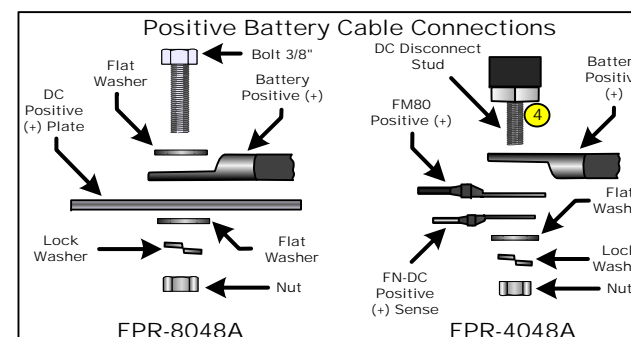

**CAUTION: Equipment Damage**  
When connecting cables from the FP-Radian to the battery terminals, make sure to observe the proper polarity. Connecting the cables incorrectly can damage or destroy the equipment and void the product warranty.

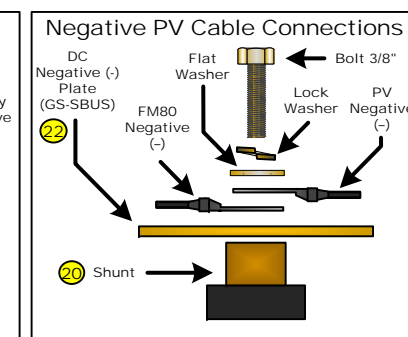
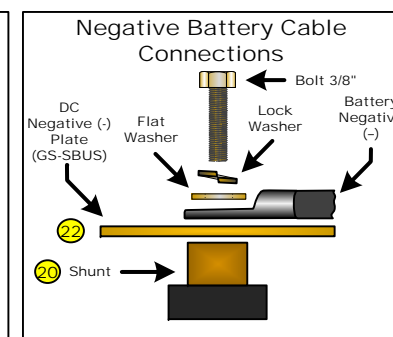

**CAUTION: Fire Hazard**  
Before energizing, confirm that all hardware is installed as shown on the Installation page. Stacking battery terminal hardware in any other order can overheat the terminals.

**Pre-startup Procedures:**

1. Double-check all wiring connections.
2. Inspect the enclosure to ensure no debris or tools have been left inside.
3. Disconnect all AC loads at the backup (or critical) load panel.
4. Disconnect the AC input feed to the GSLC at the source.

**To energize or start the OutBack devices:**

1. Using a digital voltmeter (DVM), verify 48 Vdc on the DC input terminals by placing the DVM leads on (1a) and (1b).

**Confirm that the battery voltage is correct for the inverter and charge controller models.**

**Confirm the polarity.**

**CAUTION: Equipment Damage**  
Incorrect polarity will damage the equipment.

2. Turn on (close) the GFDI circuit breaker. **1**
3. Verify that the PV input for each charge controller is in the correct range of open-circuit voltage and confirm the polarity by:
  - a) placing the DVM leads on (2a) and (1b), and
  - b) placing the DVM leads on (2b) and (1b).
4. Turn on (close) the PV input circuit breakers. **2**
5. Turn on (close) the DC circuit breakers from the battery bank to the inverter. **3**
6. If the inverter is in the Off state, turn it On. **4**
7. Turn on (close) the AC output circuit breakers. **5**
8. Verify 120 Vac on the AC Output L1 TBB by placing the DVM leads on (3a) and (3c).
9. Verify 120 Vac on the AC Output L2 TBB (3b) and (3c).
10. Verify 240 Vac between the AC Output TBBs by placing the DVM leads on (3a) and (3b).
11. Start the generator if appropriate. Verify 120/240 Vac on the terminals of the AC input sources.
12. Turn on the AC input feed to the GSLC at the source.
11. Verify 120 Vac on the GRID IN L1 TBB by placing the DVM leads on (4a) and (3c).
12. Verify 120 Vac on the GRID IN L2 TBB (4b) and (3c).
13. Verify 240 Vac between the GRID IN TBBs by placing the DVM leads on (4a) and (4b).
14. Verify 120 Vac on the GEN IN L1 TBB by placing the DVM leads on (5a) and (3c).
15. Verify 120 Vac on the GEN IN L2 TBB (5b) and (3c).
16. Verify 240 Vac between the GEN IN TBBs by placing the DVM leads on (5a) and (5b).
17. Turn on (close) the AC input circuit breakers. **6**
18. Turn on the AC disconnects at the backup (or critical) load panel and test the loads.

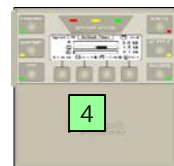
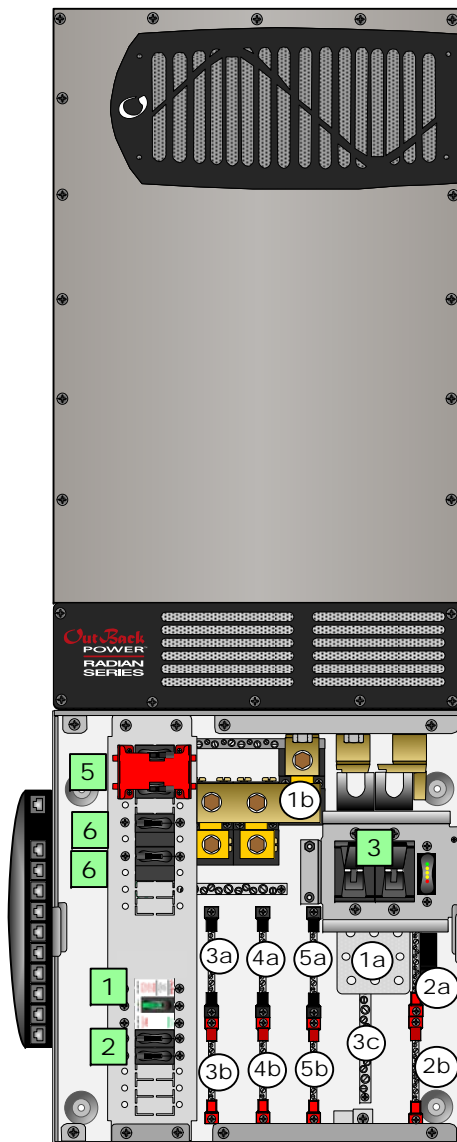

**NOTE:**  
The MATE3 system display retains factory default settings. Configuration for this system may be necessary before commissioning.  
  
See Setup and Programming for more information.

**Functional Test Points**

<b>Battery Voltage Test Points</b>	(1a) (1b)
<b>PV Voltage Test Points</b>	(2a) (2b) (2c) (2d) (1b)
<b>AC OUT Voltage Test Points (Terminal bus bar = TBB)</b>	(3a) (3b) (3c)
<b>GRID IN Voltage Test Points (Terminal bus bar = TBB)</b>	(4a) (4b) (3c)
<b>GEN IN Voltage Test Points (Terminal bus bar = TBB)</b>	(5a) (5b) (3c)

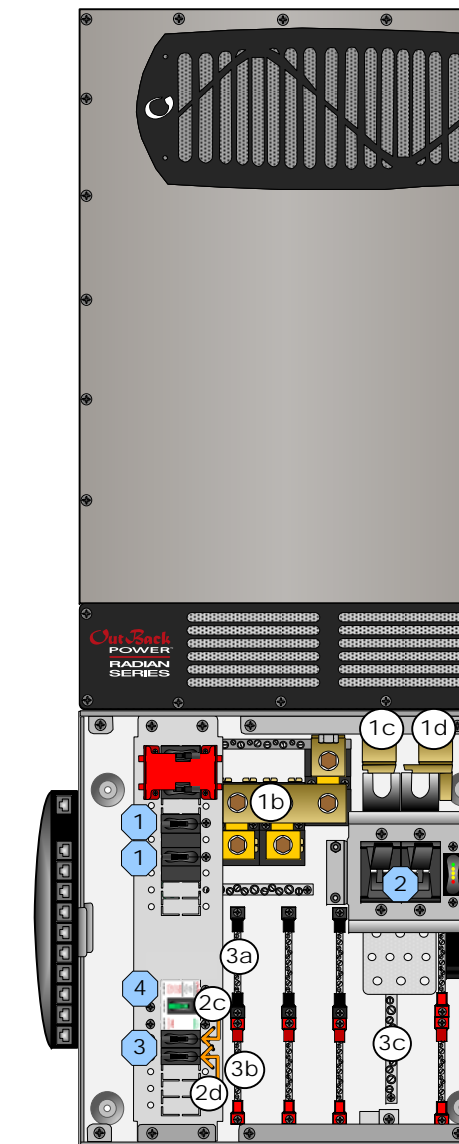

Test points 2c and 2d refer to the right terminal of each circuit breaker.

**Functional Test Points**

<b>Battery Voltage Test Points</b>	(1a) (1b) (1c) (1d)
<b>PV Voltage Test Points</b>	(2a) (2b) (2c) (2d) (1b)
<b>AC OUT Voltage Test Points (Terminal bus bar = TBB)</b>	(3a) (3b) (3c)

**WARNING: Burn Hazard**  
Internal parts can become hot during operation. Do not remove the cover during operation or touch any internal parts. Be sure to allow them sufficient time to cool down before attempting to perform any maintenance.

**WARNING: Lethal Voltage**  
Review the system configuration to identify all possible sources of energy. Ensure ALL sources of power are disconnected before performing any installation or maintenance on this equipment. Confirm that the terminals are de-energized using a validated voltmeter (rated for a minimum 1000 Vac and 1000 Vdc) to verify the de-energized condition.

**WARNING: Lethal Voltage**  
The numbered steps will remove power from the inverter and charge controllers. However, sources of energy may still be present inside the GSLC and other locations. To ensure absolute safety, disconnect ALL power connections at the source.

**To de-energize or shut down the OutBack devices:**

1. Turn off (open) the AC circuit breakers. **1**
2. Turn off (open) the DC circuit breakers for the battery. **2**  
Wait 5 minutes for the devices to internally discharge themselves.
3. Turn off (open) the PV circuit breakers. **3**
4. Turn off (open) the GFDI circuit breaker. **4**
5. Verify 0 Vdc on the first DC bus of the inverter by placing the voltmeter leads on (1b) and (1c).
6. Verify 0 Vdc on the second DC bus by placing the voltmeter leads on (1b) and (1d).
7. Verify 0 Vdc on one PV circuit by placing the voltmeter leads on (2c) and (1b).
8. Verify 0 Vdc on the other PV circuit by placing the voltmeter leads on (2d) and (1b).
9. Verify 0 Vac on the AC output circuit breakers by placing the voltmeter leads on (3a) and (3c). Repeat this step for (3b) and (3c).

## AC Distribution Panel



**AC LEGEND**

Neutral	N
HOT L1	L1
HOT L2	L2
Ground	⊕

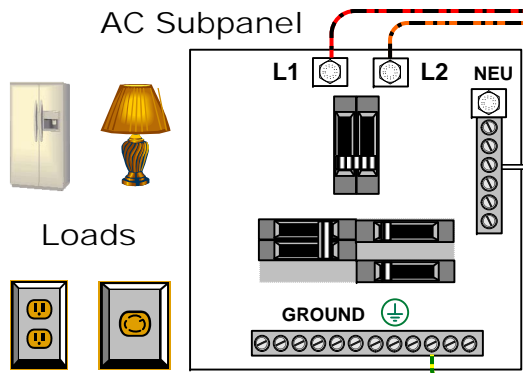
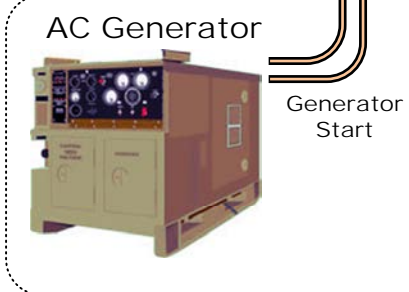
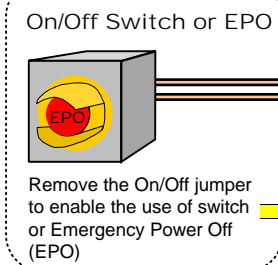

## FPR-8048A wiring and external system

**IMPORTANT:**  
Example only. Actual wiring may vary depending on system details and local electric code. Most factory wiring is not shown.

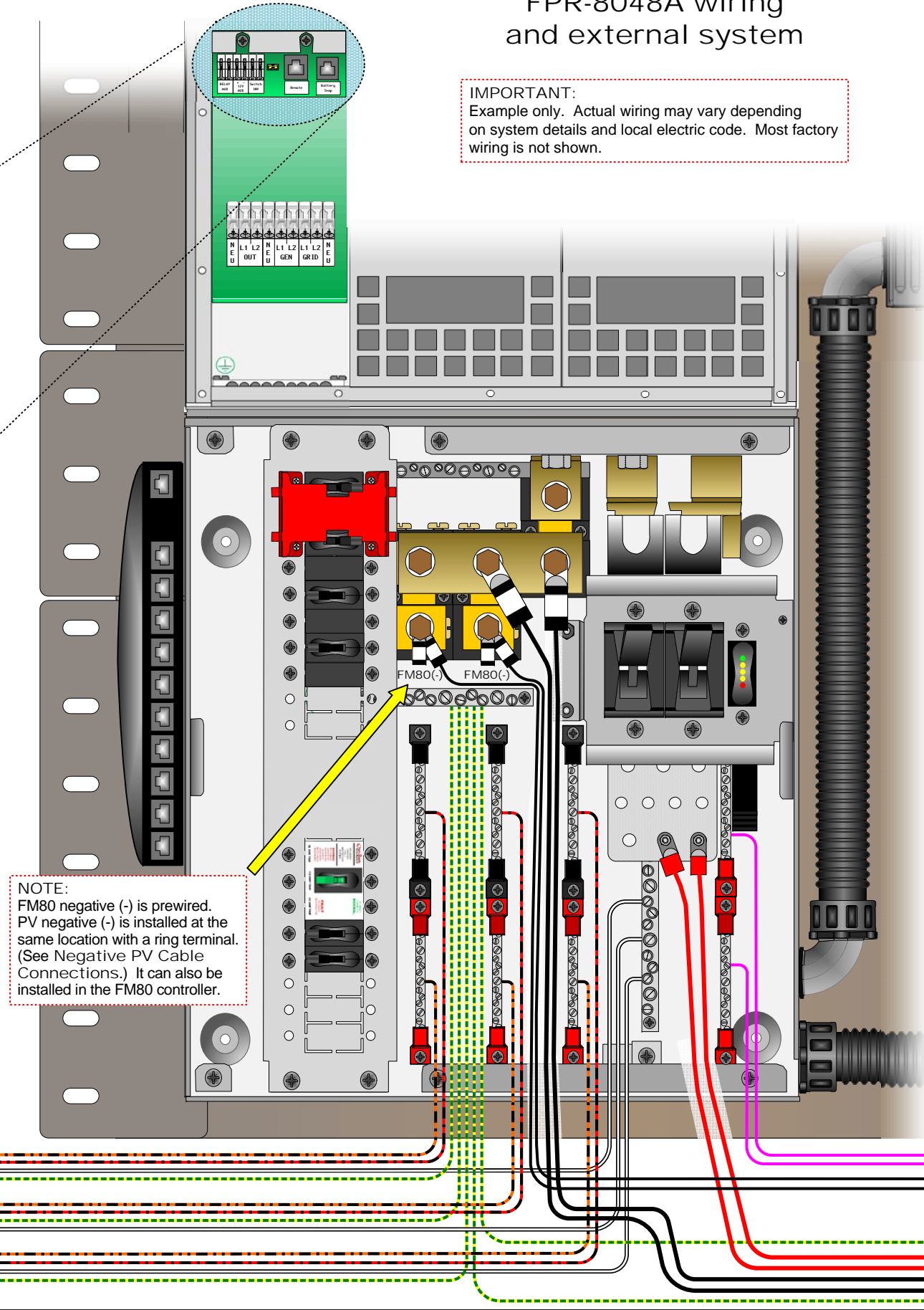

**NOTE:**  
FM80 negative (-) is prewired. PV negative (-) is installed at the same location with a ring terminal. (See Negative PV Cable Connections.) It can also be installed in the FM80 controller.

## FPR-4048A wiring

The FPR-4048A follows the same wiring layout as the FPR-8048A with the following exceptions (depicted):

- No DC positive (+) plate is present. A single positive battery cable is used. The positive cable lug connects to the base of the main DC disconnect (with the GFDI cable). See Positive Battery Cable Connections on the Installation page.
- A single battery negative (-) cable is used. It connects to the far right shunt.
- A single PV positive (+) and bus bar are used.
- A single PV negative (-) cable is used. It connects to the far left shunt. See Negative PV Cable Connections.

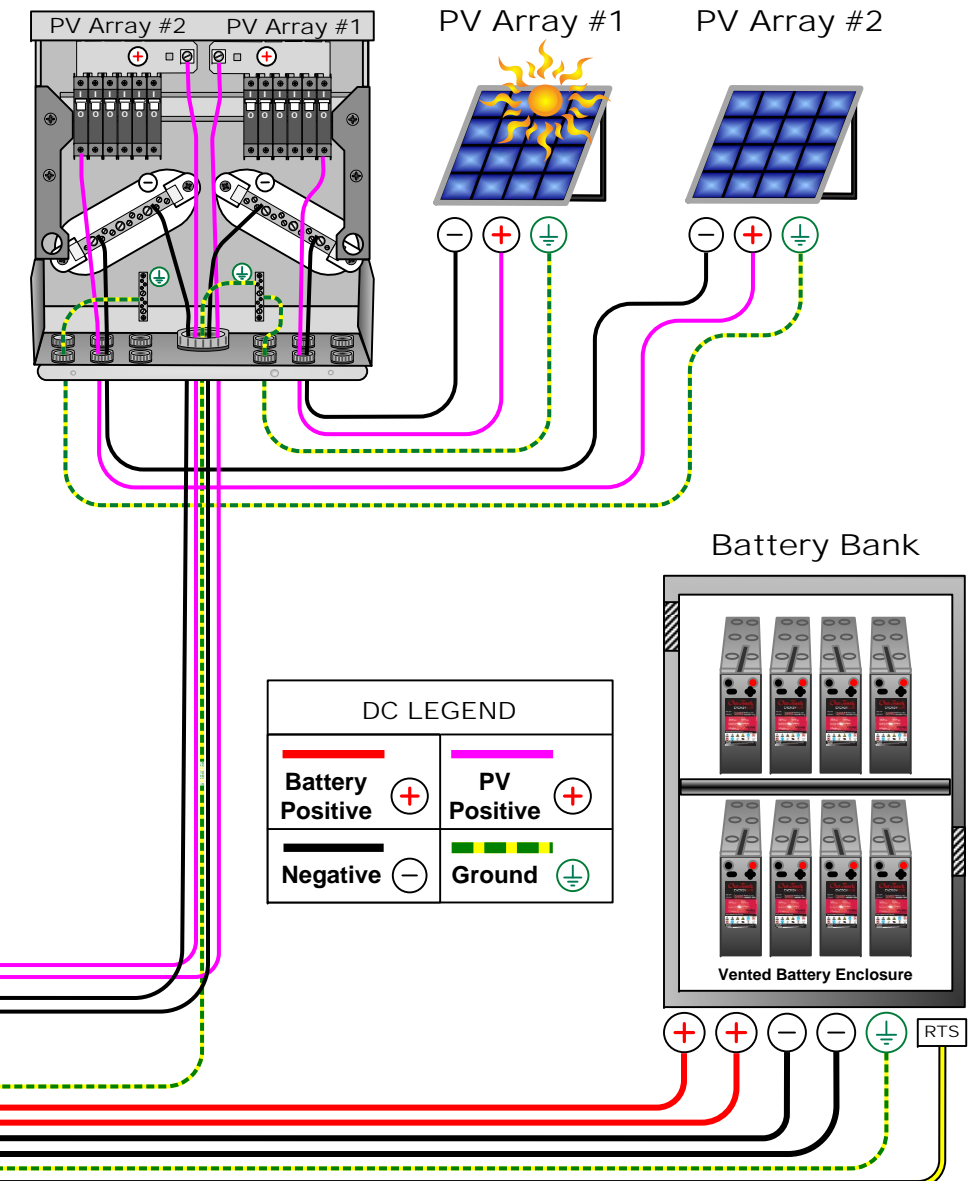
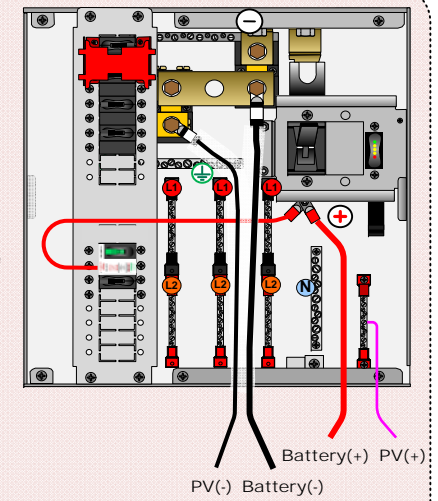

**DC LEGEND**

Battery Positive	+	PV Positive	+
Negative	-	Ground	⊕

Battery (+) PV (+)  
PV (-) Battery (-)